

fullstop[®]
SECURITY

EXCALIBUR

Model. FRL100-8

Caravan Security



**PLEASE READ THIS
MANUAL BEFORE
FIRST USE.**

**TIME INVESTED IN
CORRECT FITMENT
IS REPAID IN THE
LEVEL OF SECURITY
THAT IS ACHIEVED.**

User Manual

Rev.C 01-10

by  **purpleline**[®]
design...innovate...improve

Parts Identification

1. Shield Section
2. Lock
3. Bolt Receiver
4. Bolt
5. Hex Tool
6. 10mm Spacer
7. 7mm Spacer
8. 5mm Spacer
9. Keys (x2)

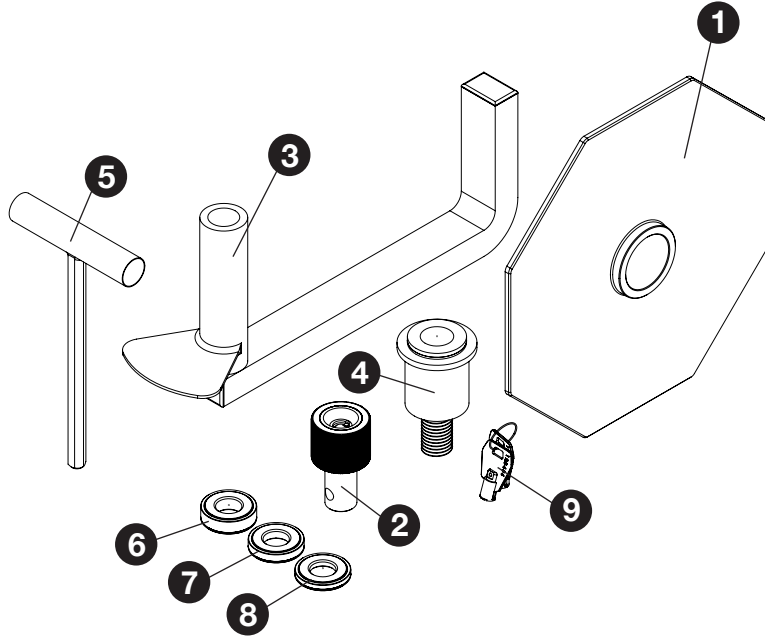

CAUTION!
BE CAREFUL
OF POTENTIAL
SURFACE
DAMAGE
TO ALLOY
WHEELS WHEN
POSITIONING/
FITTING THE
EXCALIBUR.

Fig.A

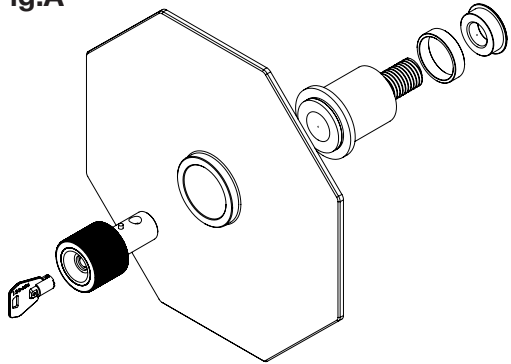

Fig.B

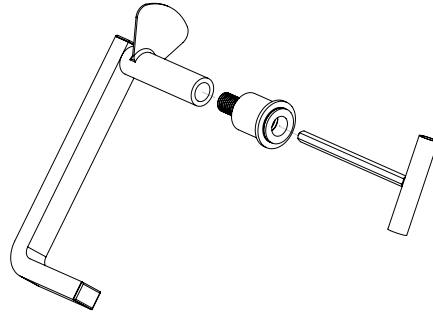

Fig.C

The fit of the Excalibur can be adjusted as necessary using the supplied 10mm, 7mm & 5mm spacers in any combination as appropriate. The spacers simply screw onto the bolt. Ensure the lip of the spacer is facing towards the end of the bolt in order to retain the freely rotating collar.



No spacer fitted.



With 10mm spacer fitted.

Installation

CAUTION!

Be careful of potential surface damage to alloy wheels when positioning/fitting the Excalibur.

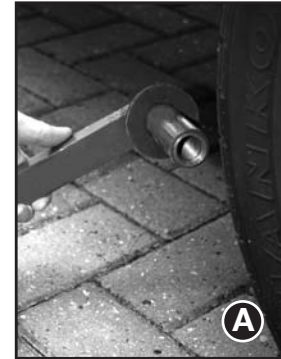

NOTE:
Only suitable for factory fitted alloy wheels.

A. Offer up the Bolt Receiver arm (3) to the caravan wheel from the side.

C. Insert the hex tool (5) into the bolt (4). Line up the bolt to the bolt receiver's (3) threaded aperture. (see Fig.B)

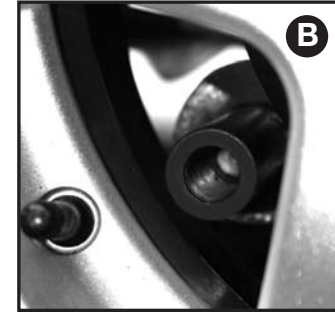

B. Position the Bolt Receiver (3) so that the threaded aperture is accessible through a gap in the spokes of the alloy (it may be necessary to rotate the wheel slightly).



D. Screw in turning clockwise until as tight as possible. *Caution: Hand tight only.*

E. (see Fig.A & Fig.B for guidance)

The lock (2) is already fitted through the shield portion (1) in a locked state.

Insert the key into the lock (2), push and turn 45° clockwise to release the locking mechanism.

Fit the Lock (2) into the bolt (4), once inserted turn the key 45° anti-clockwise and remove the key.

If the key cannot be turned 45° anti-clockwise and removed, it is likely that the male lock portion cannot fully engage into the bolt. If this occurs the bolt needs to be extended using one or more of the spacers (see Fig.A & Fig.C for details on spacers).

Ideally, when properly fitted there shouldn't be a gap any larger than approx. 5mm between the face of the alloy wheel and the back face of the shield.

F. Please store your keys in a safe place and remember to return your fully completed registration card. Your key number is located on both of the keys supplied and will be required in order to purchase replacement keys.





Disclaimer

If used properly, your FullStop® product will be an effective deterrent. However, nothing can stop the efforts of the most determined thief, and to this end no liability is accepted for any loss and/or damage caused by any illegal activity including theft or vandalism. Liability also not accepted for any loss and/or damage arising from misuse, unauthorised repair or alteration and failure to follow the user guide directions. No form of consequential loss what so ever will be accepted.



© Copyright 2010. Purple Line Limited.

Web: www.purpleline.co.uk **E-mail:** admin@purpleline.co.uk **Tel:** 01473 601200

Photographs for illustration purposes only. Actual product may differ slightly.

Purple line Limited reserve the right to alter product specification without prior notice.