







Safety in Use!

-  The AeroPlus is subjected to very high wind forces whilst in use. Please ensure that all fixings are suitably secure and check the fittings at regular intervals during any journey.
-  Please be aware that the overall height of your vehicle will have increased by approximately 0.3m when the AeroPlus is fitted. Beware of height restriction barriers and low entrances such as garages.
-  Do not use any form of automated car wash when the AeroPlus is fitted. This will damage the AeroPlus, your vehicle and could prove dangerous.
-  When travelling with the AeroPlus fitted, always adhere to the national speed limit regulations applicable when towing a caravan. Speed limits vary in Europe so please check regional regulations.
-  Do not exceed 60 Mph/96 Km/h (even if legally permitted to do so) when using the AeroPlus.
-  Do not use the AeroPlus if the unit or any of its accessories are missing or damaged in any way.

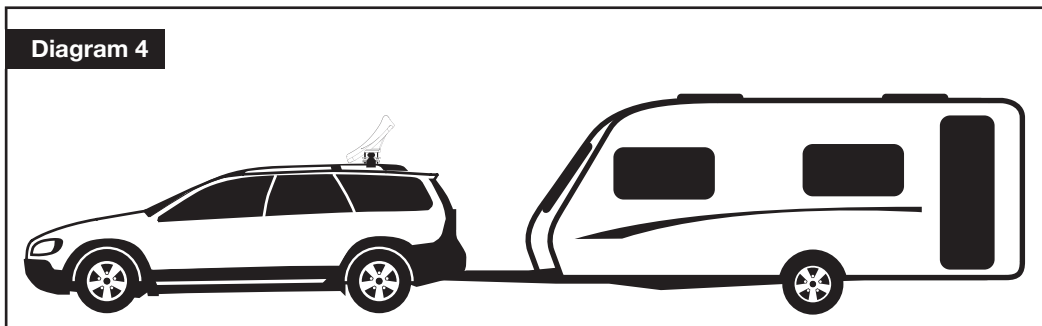
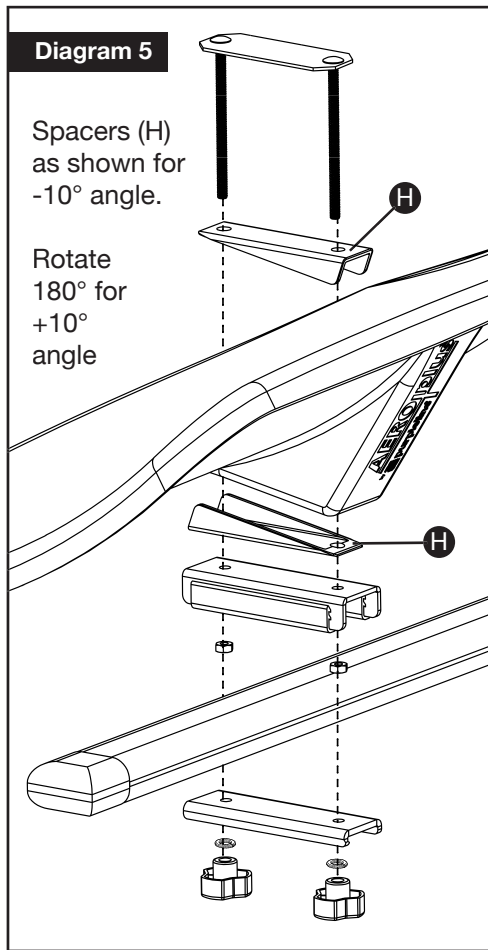

 **purpleline**[®]
design...innovate...improve
www.purpleline.co.uk

© 2009 Purple Line Limited. Photographs are for illustration purposes only. Actual product may differ. Purple Line Limited reserve the right to change product specifications without prior notice. This product was tested by the Motor Industry Research Association (MIRA) and the use of the 'MIRA' logo does not constitute an endorsement from this association.

AEROplus

Proven to Reduce Drag and Improve Stability

User Guide

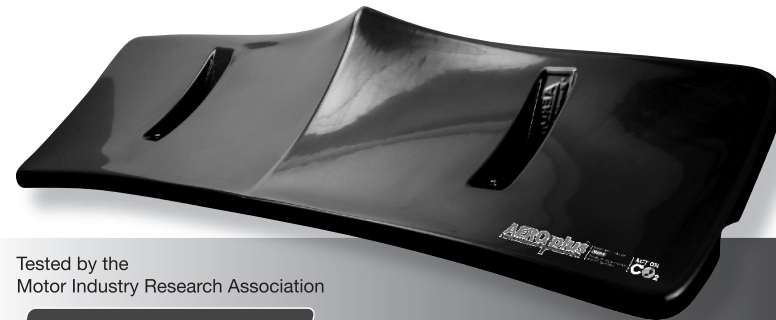

Tested by the
Motor Industry Research Association



by  **purpleline**[®]
design...innovate...improve

| Ref. | Part Description | Qty |
|------|---|-----|
| A | Aeroplus Deflector | 1 |
| B | Upper Bracket Plate with integral bolts | 2 |
| C | Middle Bracket | 2 |
| D | Nylock Nuts | 4 |
| E | Lower Bracket | 2 |
| F | Spring Washers | 4 |
| G | Plastic Knobs | 4 |
| H | Angle Adjustment Spacers | 4 |

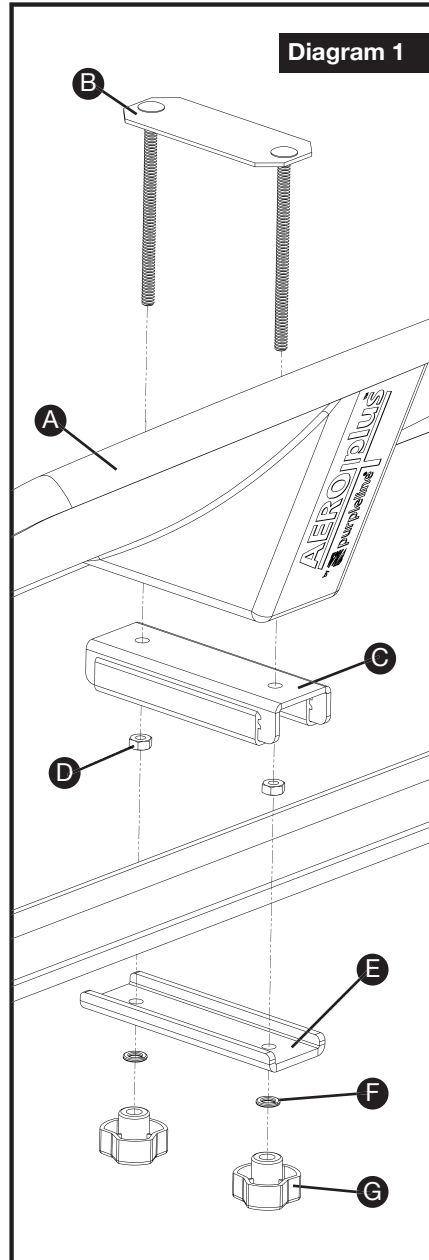
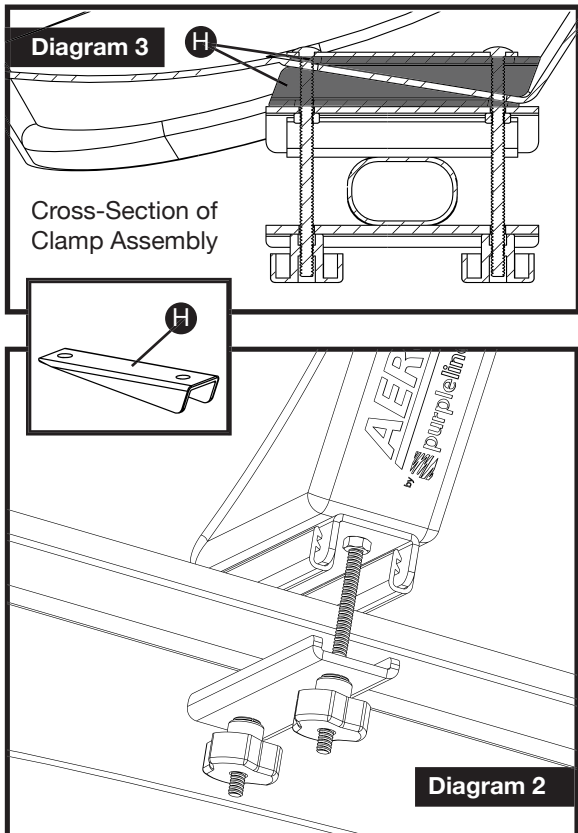

Introduction

The Aeroplus is designed to drive the flow of air more smoothly over the top of your caravan - reducing drag, increasing towing stability and increasing fuel economy.

Please read this User Guide fully prior to use and retain for future reference.

Assembly

The Aeroplus brackets are designed to fit onto most standard roof bars with a bar height up to 35mm. Note: If the optional Angle Adjustment Spacers (H) are utilised the overall height of the clamp assembly is increased by approx. 20mm, so please ensure there is enough thread on the Upper Bracket Bolts (B) to securely attach the deflector.

Prior to Aeroplus fitment, attach a suitable roof bar to the rear of your vehicle. If your vehicle is fitted with longitudinal roof rails (present on some 4x4s, estate cars and MPVs), you should attach the roof bar as far as possible towards the rear of the vehicle. (please see Diagram 4 for guidance).

To fit the Aeroplus, start by fitting the Upper Bracket Bolts (B) through the apertures on both mounting points on the Aeroplus (A), fit the Middle Brackets (C) and secure with the Nylock nuts (D).

Position the Aeroplus central to the width of the roof bar and secure with the Lower Brackets (E), the Spring Washers (F) and the Knobs (G). Ensure all fixings are suitably secure.

The Aeroplus is now ready for use. Note: Remember to remove from your car when you are not towing your caravan.

To remove, reverse the procedure on parts (E), (F) and (G). Keep the loose components in a safe place.

Fitment of Angle Adjustment Spacers

The Spacers (H) will alter the default angle of the Aeroplus by $\pm 10^\circ$ degrees approximately. In order to optimise performance, it may be necessary to make alterations, as every car/caravan set-up is different.

If required, fit the Spacers (H), one in-between the Aeroplus (A) and the Upper Bracket (B) and one in-between the underside of the Aeroplus (A) and the Middle Bracket (C). If the angle needs to be steeper, fit the top Spacer (H) with the thick end facing the front of the vehicle, to reduce the angle, reverse the Spacer (please see Diagrams 3 & 5).